

SAP# 100674473

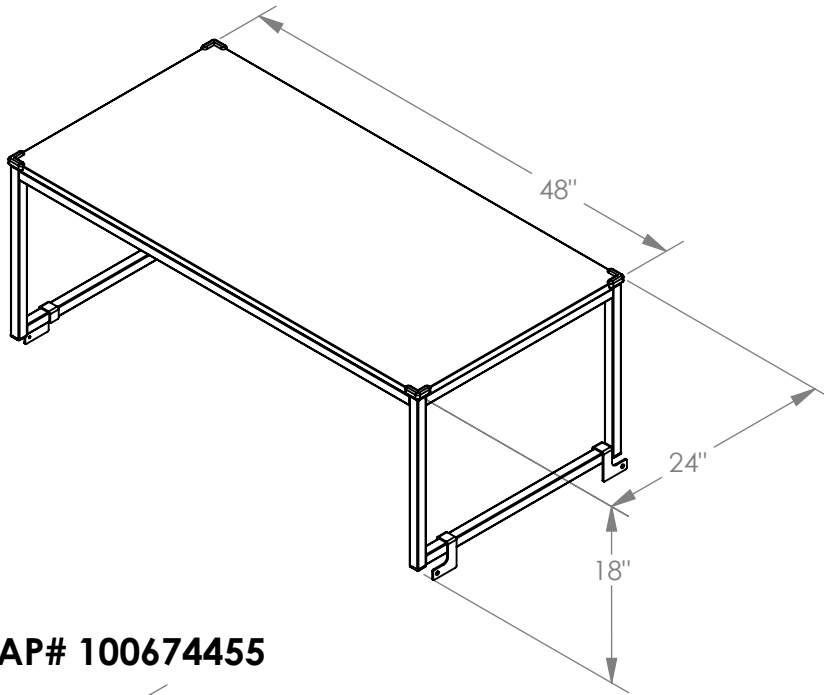

SAP# 100674455

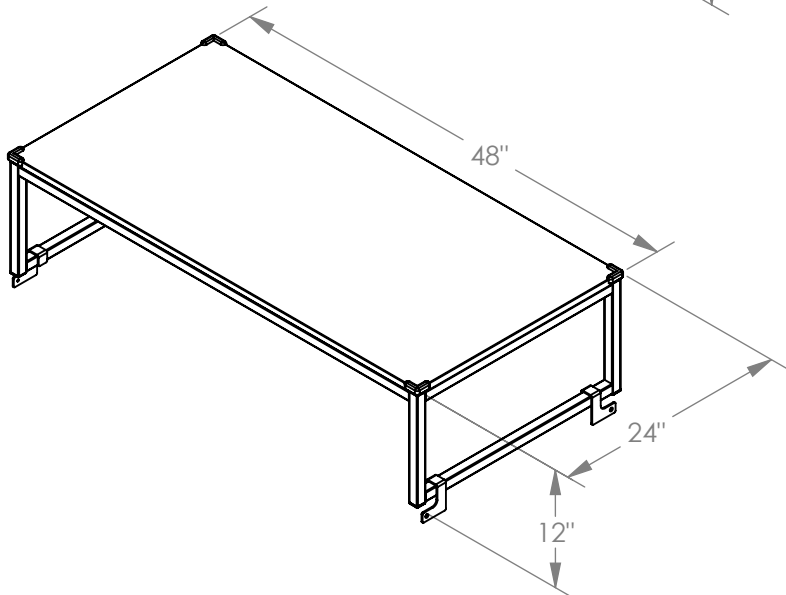

Walmart Part No.

100674473  
 100674455  
 100673476

Walmart Description

**RISER TOP ASSEMBLY 18X48**  
**RISER TOP ASSEMBLY 12X48**  
**4X4 VIGNETTE BASE CABINET 48X48X18 IN**

SAP# 100673476

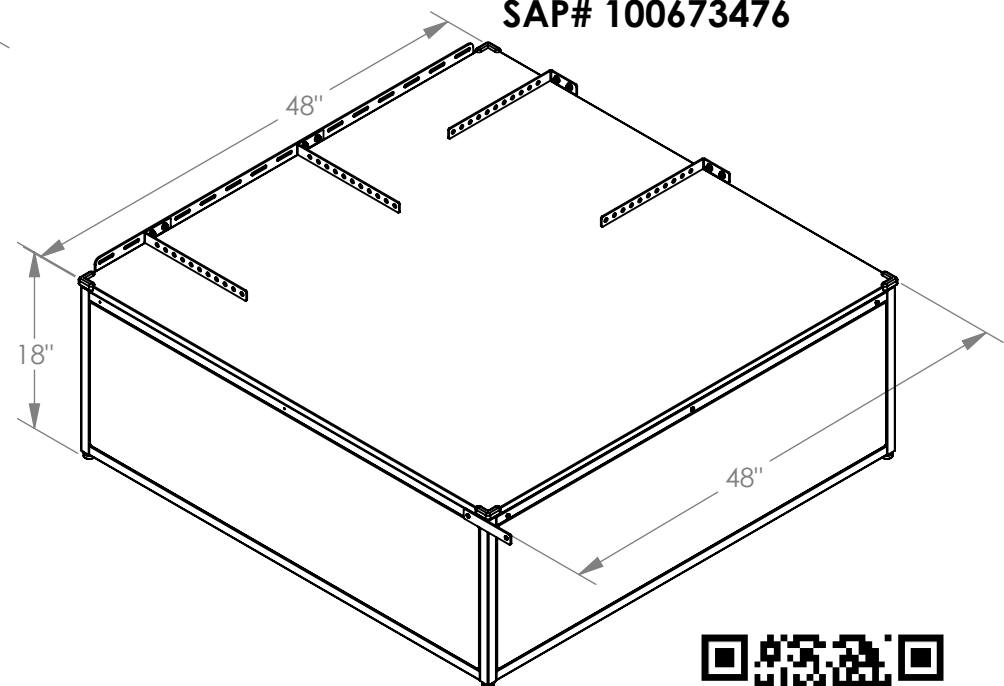

Scan the QR code or visit  
[www.ladarling.com/vignette-base/](http://www.ladarling.com/vignette-base/) for the  
 latest copy of the instruction sheets.

Customer Service 1-800-682-5730

**LADARLING**

REDEFINE. RETHINK. RETAIL SOLUTIONS.

LAD DESCRIPTION  
 VIGNETTE BASE DISPLAYS

LAD PART NO.  
 354302IS

REV.	BY	DATE
2	RP	3/25/22

Step 1: Locate Vignette Bases according to floor plan.

Step 2: Attach tie down plates where needed using provided flat head screws.

Step 3: Attach extender brackets to tie down plates where needed using provided 1/4"-20 screws and nuts.

Step 4: If multiple Vignette Riser Bases are used, connect them using provided flat head screws and vignette tie plates.

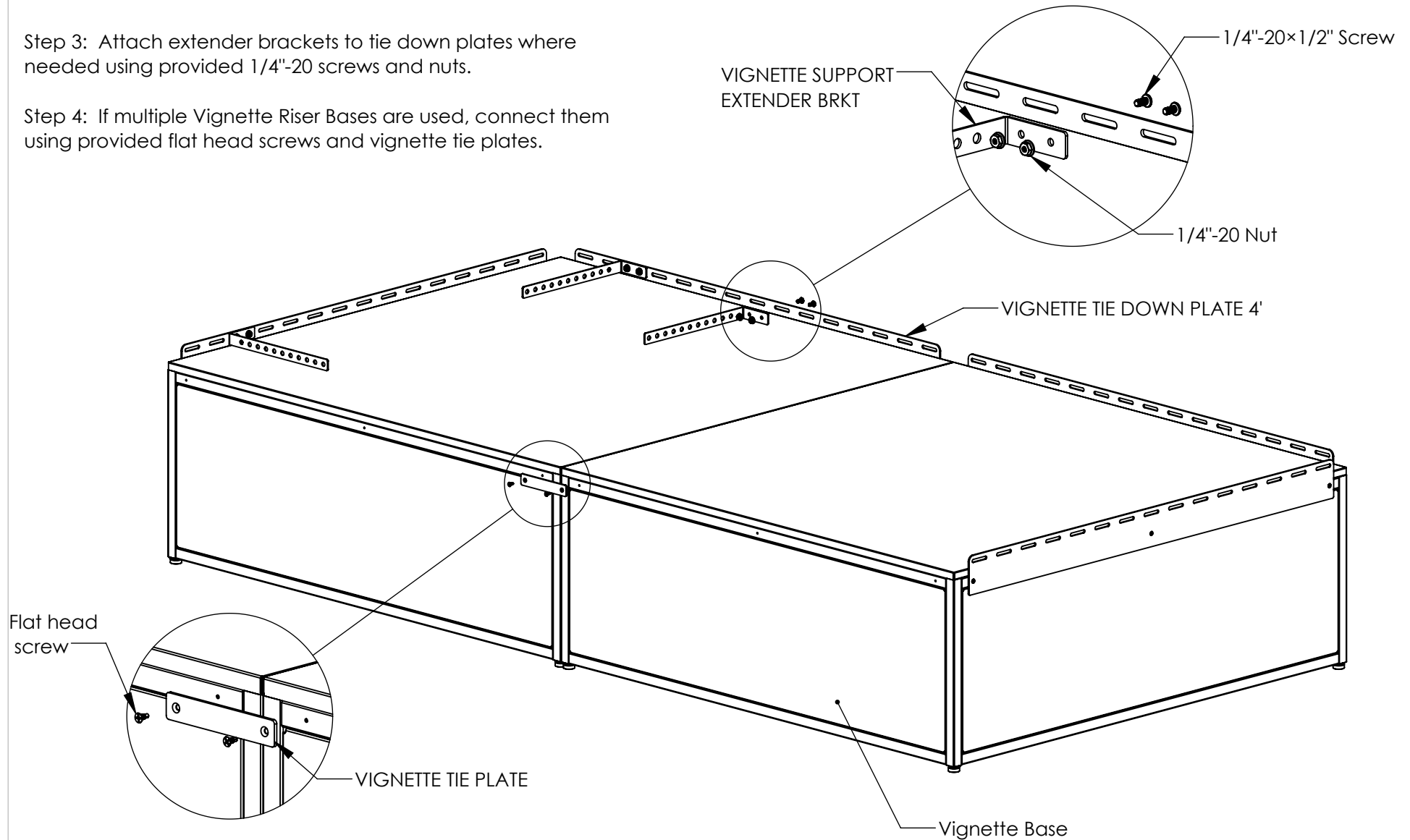

Step 5: For displays that use risers, attach Risers using a Vignette Tie Plate LH and a Vignette Tie Plate RH on each end of Riser with flat head screws.

Step 6: Attach self-adhesive corner covers to exposed corners on Vignette Bases and Risers.

